

EFREI 2011/2012

L2

Math pour l'Informatique

TAI « Automates Finis »

Automates de test

Rappels :

Vous devez préparer les fichiers de données nécessaires pour que votre programme puisse être exécuté sur tous les automates décrits dans ce document. La structure du fichier de données utilisée doit permettre à l'examineur, s'il le juge utile, de faire quelques changements en cours de soutenance, donc de façon simple et rapide.

Remarque :

Pour chaque automate, l'alphabet à prendre en compte est constitué des caractères identifiés sur au moins une des transitions. Par exemple, l'alphabet de l'automate 6 est {a,b}.

Cas particulier : l'alphabet de l'automate 1 est {a}.

#01

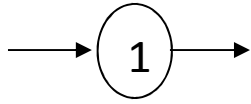

#02

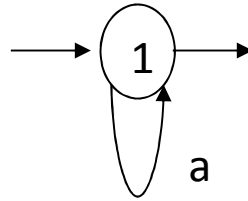

#03

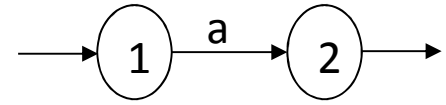

#04

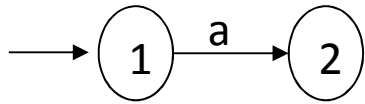

#05

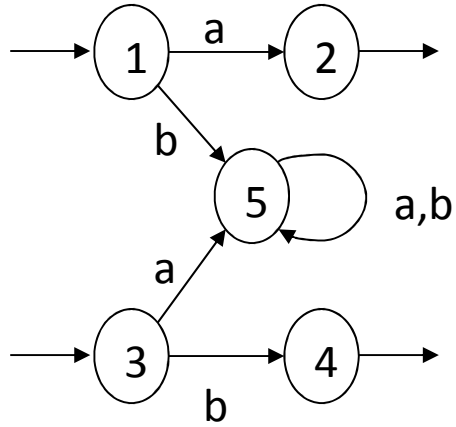

#06

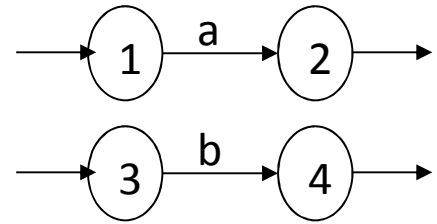

#08

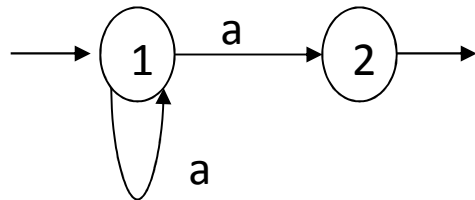

#09

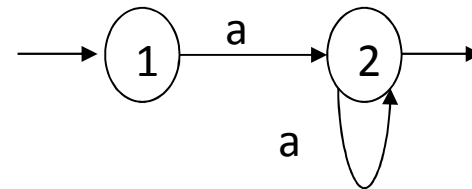

#12

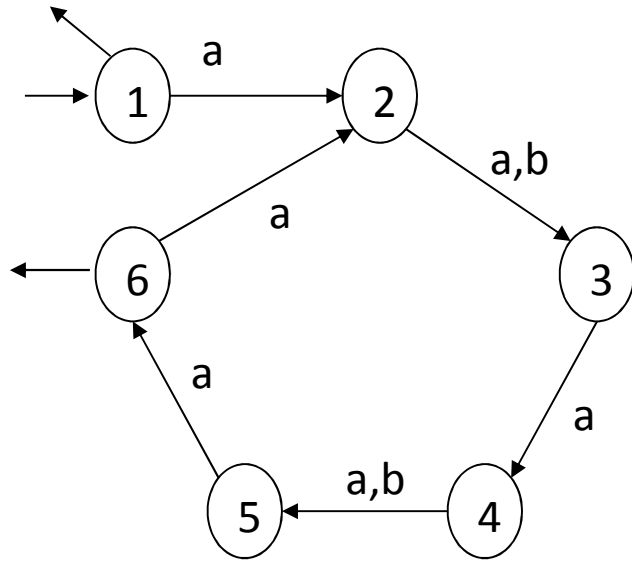

#13

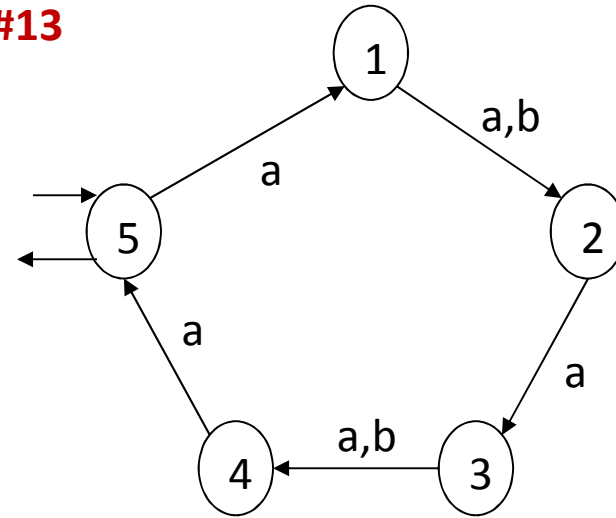

#15

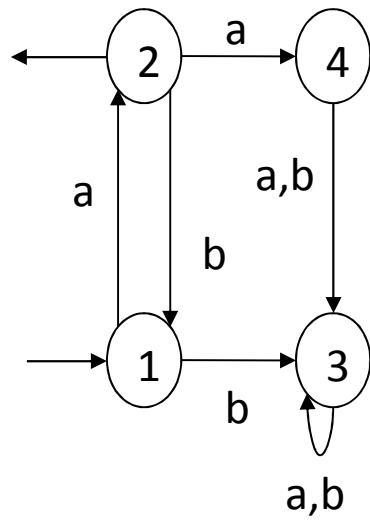

#19

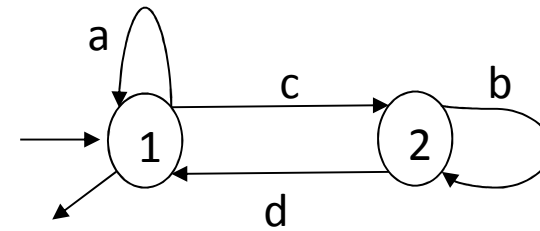

#72

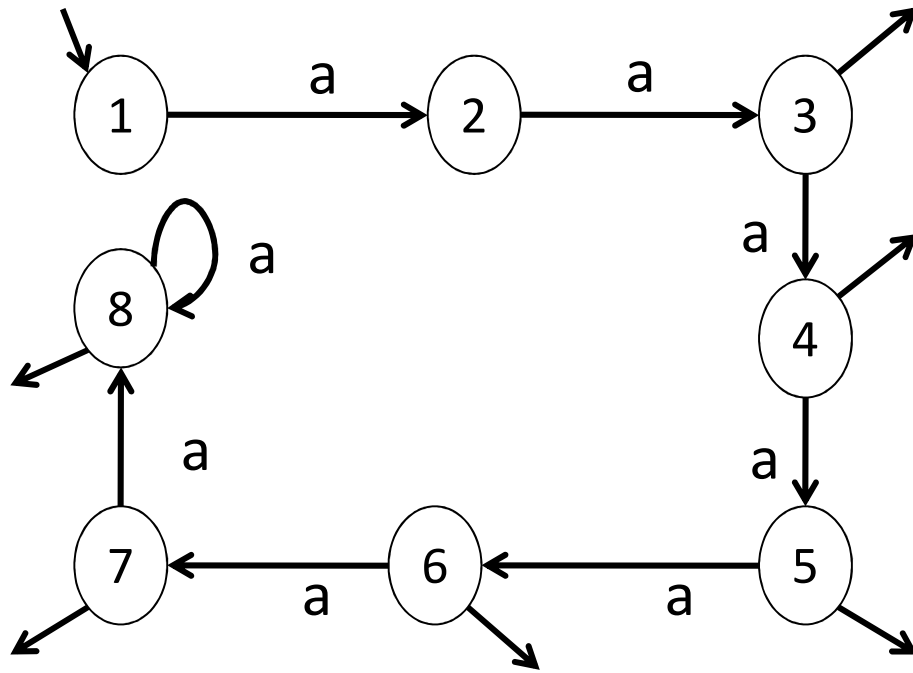

#79

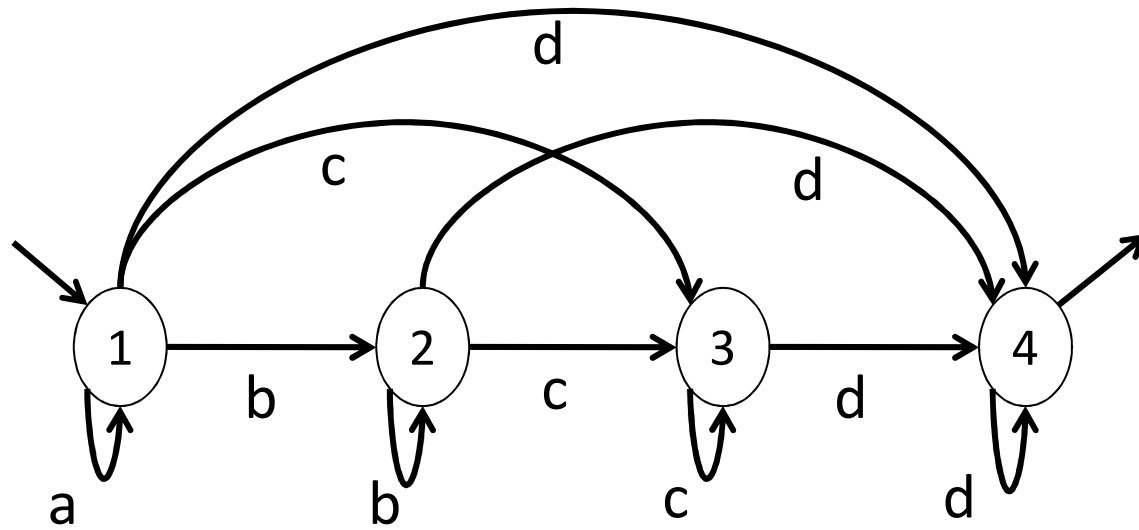

#80

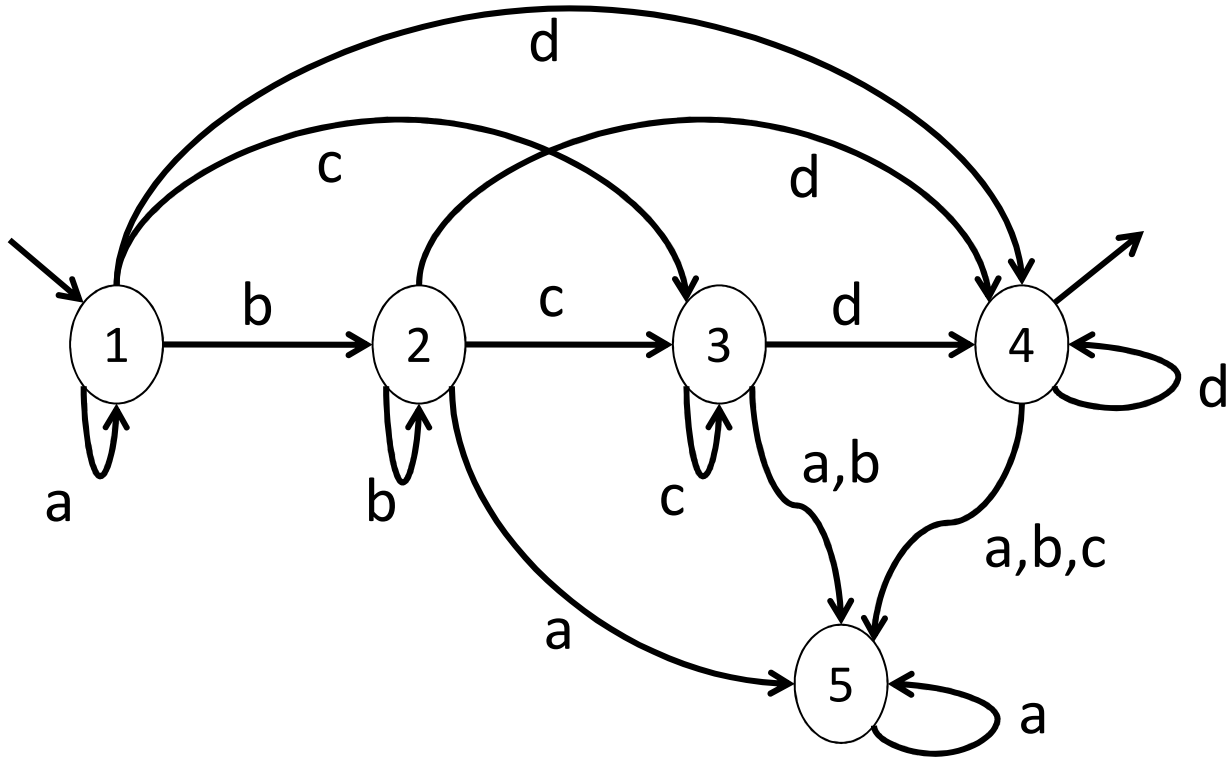

#85

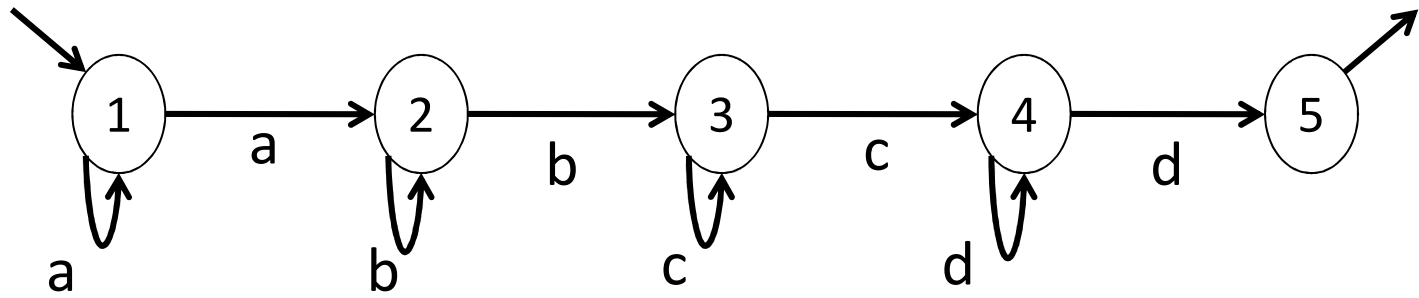

#92

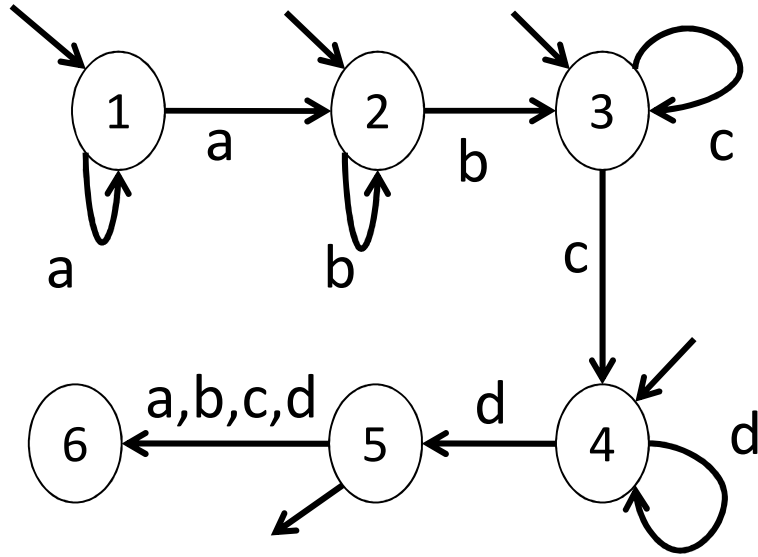

#96

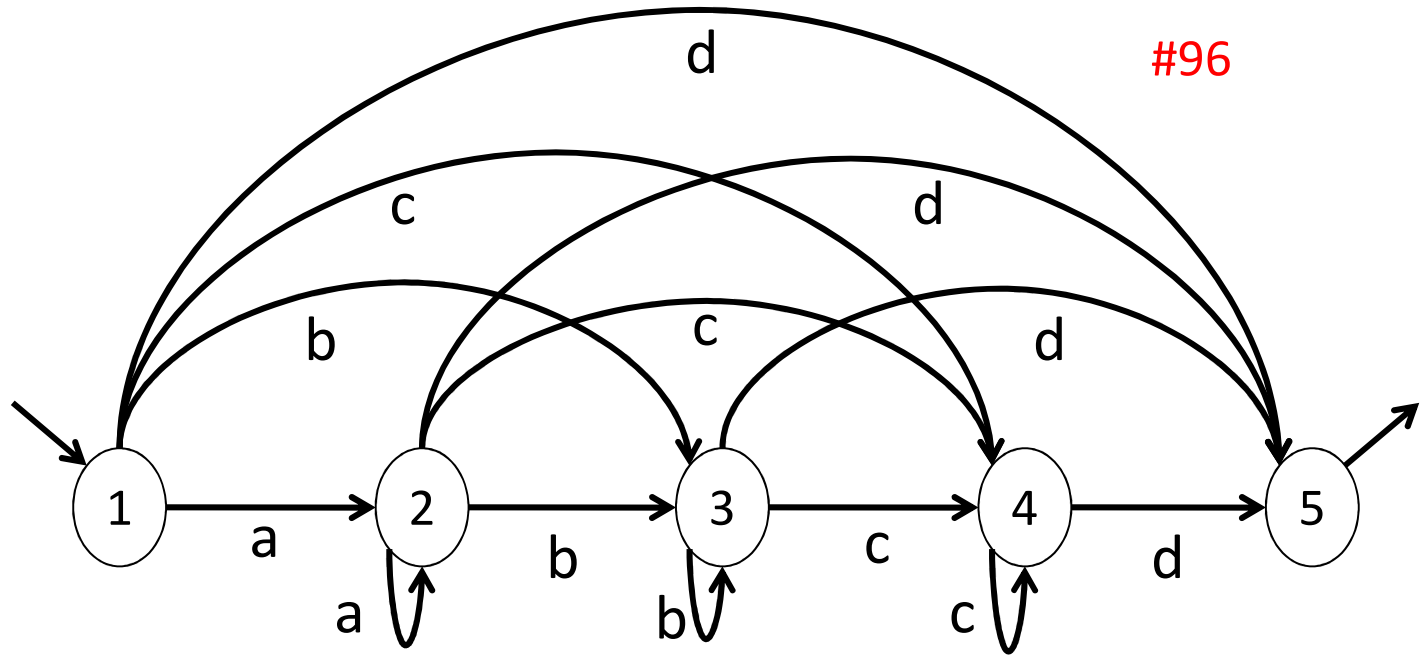

#99

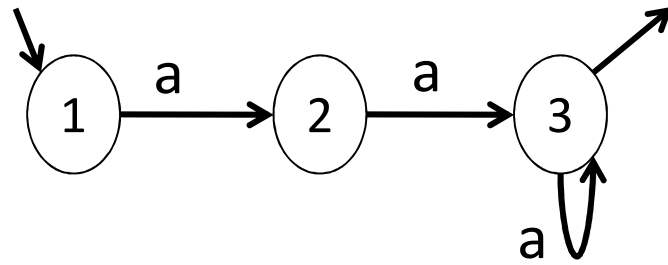

#101

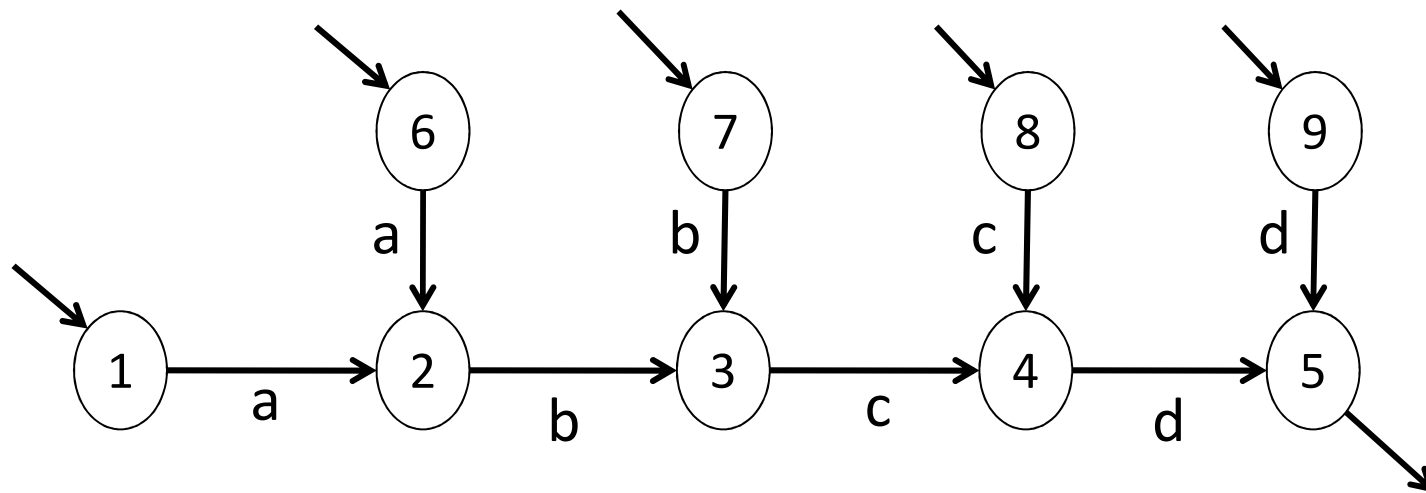

#102

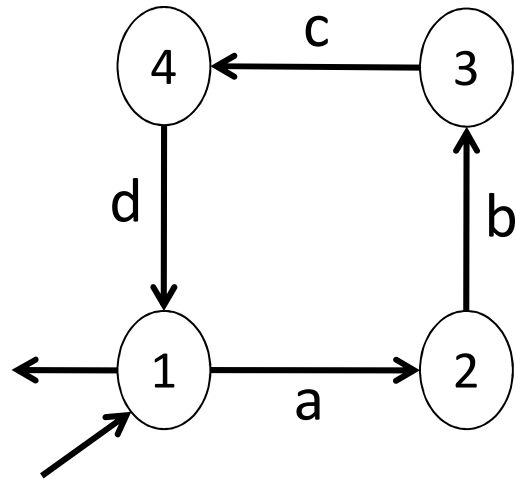

#103

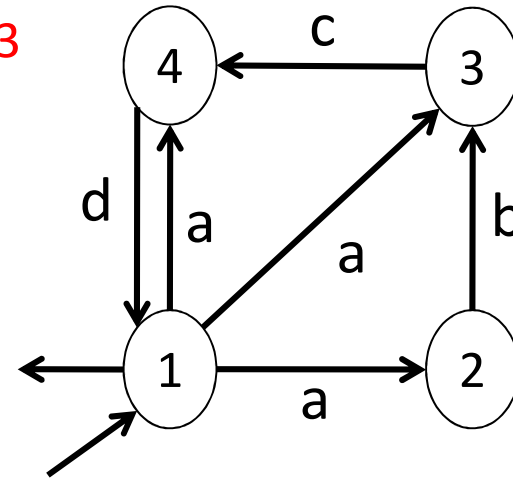

#104

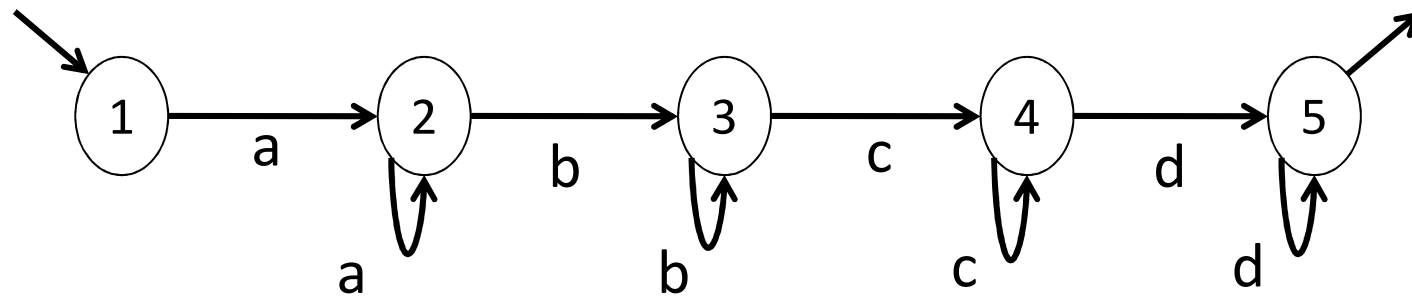

#106

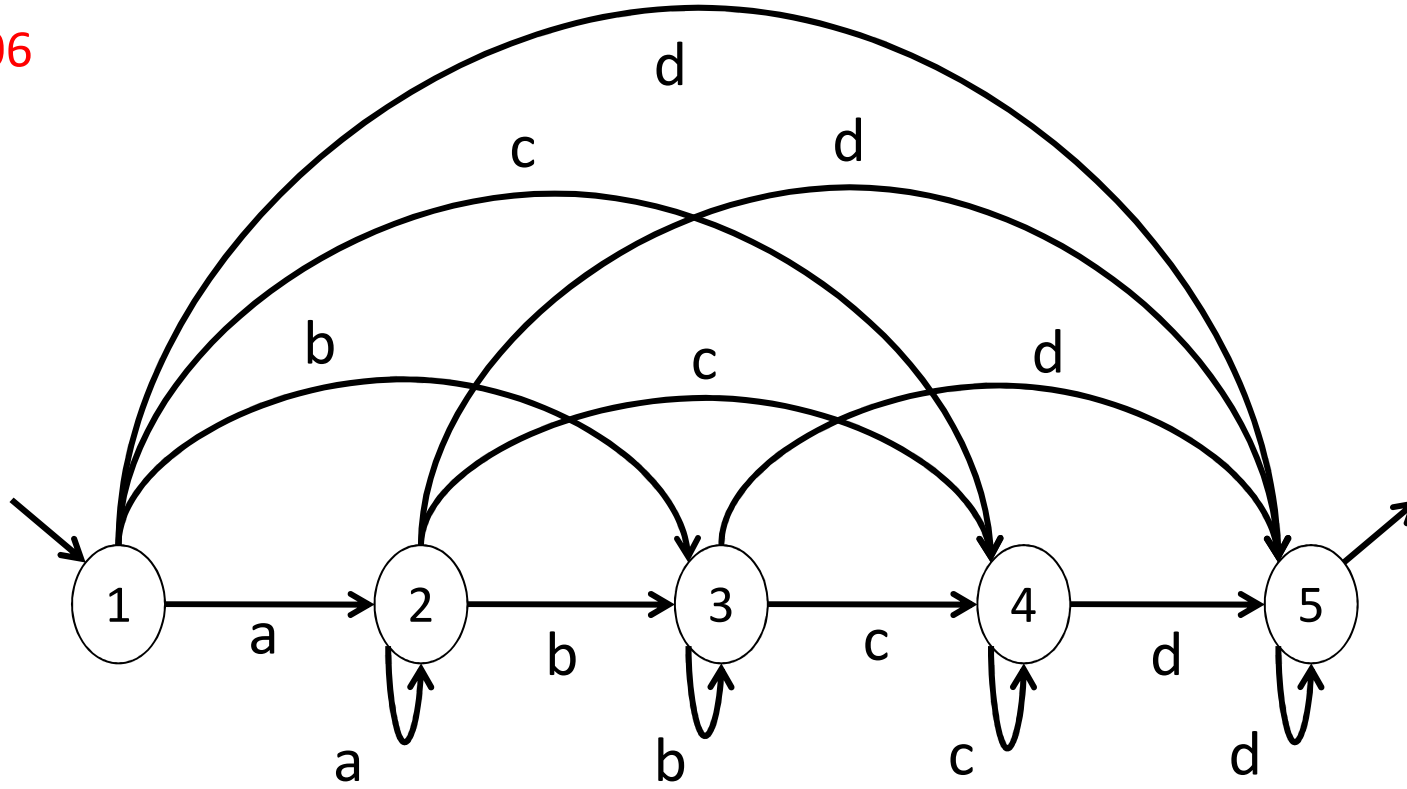

#107

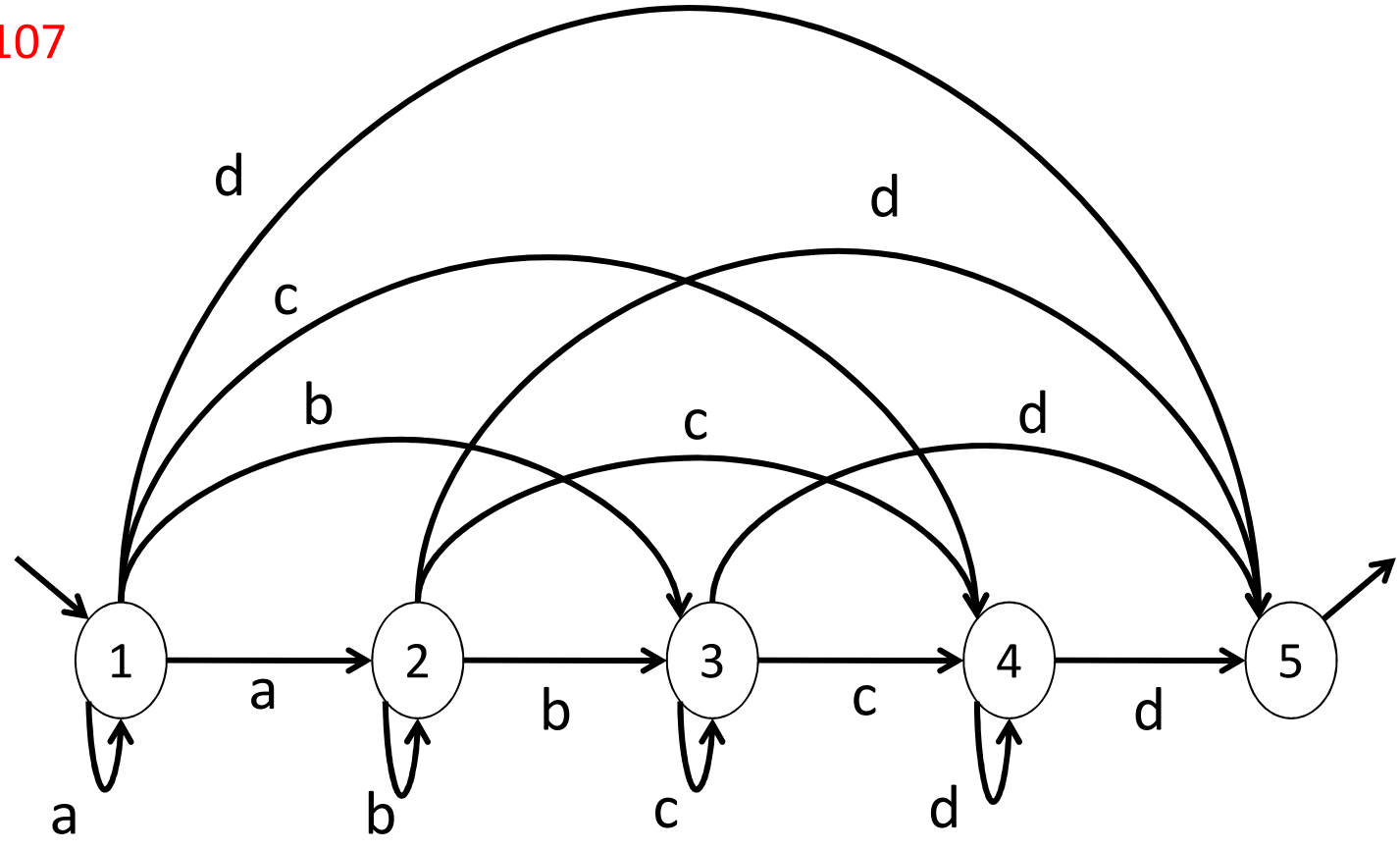

#108

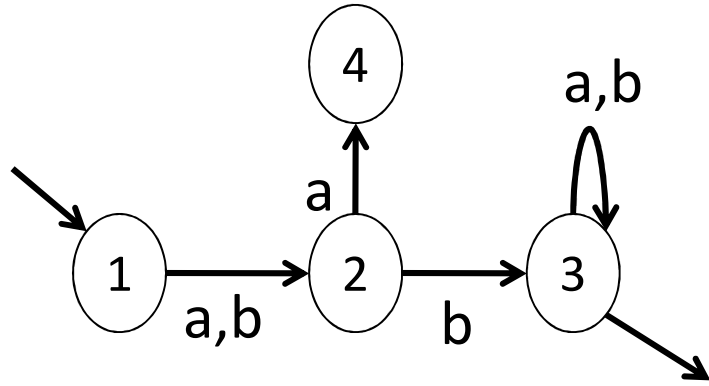

#109

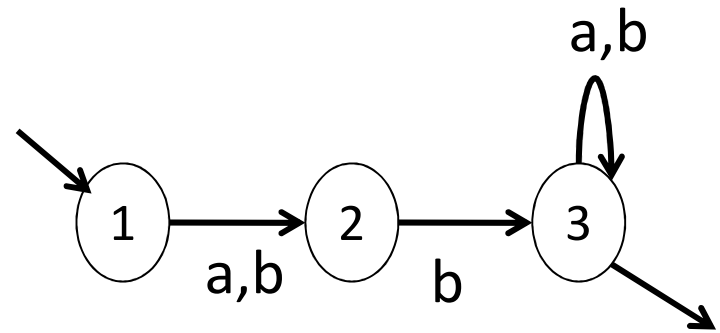

#110

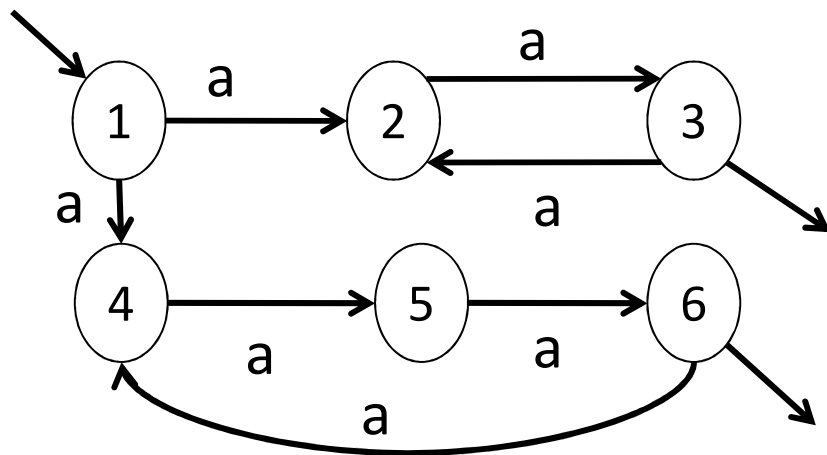

#111

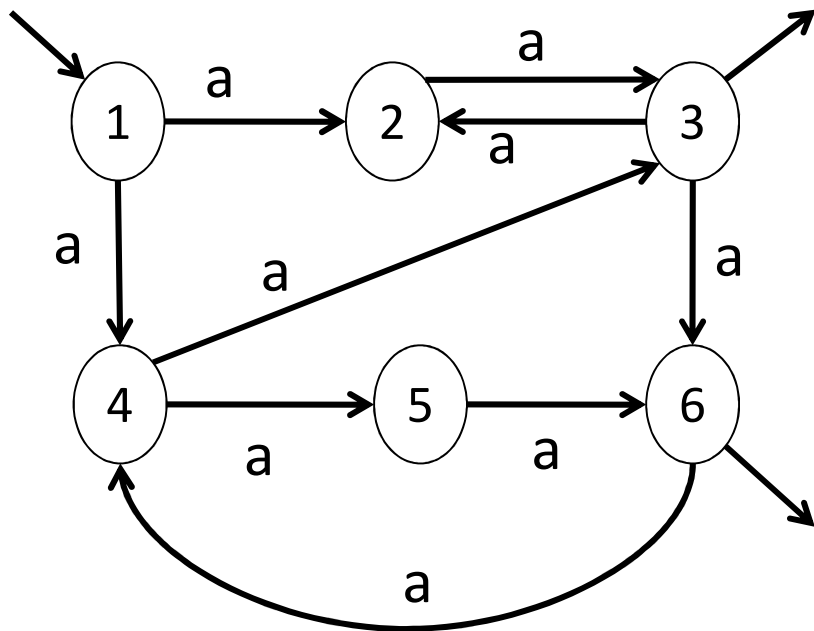

#113

